

***Installation, Service
& Maintenance Manual***

*for models
BL105, SL105, TL105G*

SAFETY PRECAUTIONS

Before operating the generating set, read the generating set operation manual and this generator manual and become familiar with it and the equipment.

SAFE AND EFFICIENT OPERATION CAN ONLY BE ACHIEVED IF THE EQUIPMENT IS CORRECTLY OPERATED AND MAINTAINED.

Many accidents occur because of failure to follow fundamental rules and precautions.

ELECTRICAL SHOCK CAN CAUSE SEVERE PERSONAL INJURY OR DEATH.

- Ensure installation meets all applicable safety and local electrical codes. Have all installations performed by a qualified electrician.
- Do not operate the generator with protective covers, access covers or terminal box covers removed.
- Disable engine starting circuits before carrying out maintenance.
- Disable closing circuits and/or place warning notices on any circuit breakers normally used for connection to the mains or other generators, to avoid accidental closure.

Observe all IMPORTANT, CAUTION, WARNING, and DANGER notices, defined as:

Important ! Important refers to hazard or unsafe method or practice which can result in product damage or related equipment damage.

Caution ! Caution refers to hazard or unsafe method or practice which can result in product damage or personal injury.



Warning !

Warning refers to a hazard or unsafe method or practice which CAN result in severe personal injury or possible death.

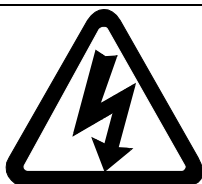

Danger !

Danger refers to immediate hazards which WILL result in severe personal injury or death.

Due to our policy of continuous improvement, details in this manual which were correct at time of printing, may now be due for amendment. Information included must therefore not be regarded as binding.

FOREWORD

The function of this book is to provide the user of the Markon generator with an understanding of the principles of operation, the criteria for which the generator has been designed, and the installation and maintenance procedures.

Each generator has been so designed, constructed, tested and examined as to ensure that it will be safe and without risk to health when properly used. Machine outputs etc. are shown on the nameplate attached to the frame.

Specific areas where the lack of care or use of incorrect procedures could lead to equipment damage and/or personal injury are highlighted, with **IMPORTANT**, **CAUTION**, **WARNING** and/or **DANGER** notes, and it is **IMPORTANT** that the contents of this book are read and understood before proceeding to fit or use the generator.

Any persons carrying out operating and maintenance procedures should wear any appropriate protective clothing and equipment, use the correct tools and observe any regulations contained in, or made pursuant, to the Health and Safety at Work Act 1974 or any other relevant statute.

The Service, Sales and technical staff of Markon are always ready to assist and reference to the company for advice is welcomed.

EC DECLARATION OF INCORPORATION

All Markon generators are supplied with a declaration of incorporation for the relevant EC legislation, typically in the form of a label as below.

Under the EC Machinery Directive section 1.7.4. It is the responsibility of the generator set builder to ensure the generator serial and identity numbers are clearly displayed in the space provided inside the back cover of this book.

<p>○</p> <p>EC DECLARATION OF INCORPORATION</p> <p>IN ACCORDANCE WITH THE SUPPLY OF MACHINERY (SAFETY) REGULATIONS 1992 AND THE SUPPLY OF MACHINERY (SAFETY) (AMENDMENT) REGULATIONS 1994 IMPLEMENTING THE EC MACHINERY DIRECTIVE 89/392/EEC AS AMENDED BY 91/368/EEC.</p> <p>THIS STAMFORD A.C GENERATOR WAS MANUFACTURED BY OR ON BEHALF OF NEWAGE INTERNATIONAL LTD BARNACK ROAD STAMFORD LINCOLNSHIRE ENGLAND</p> <p>THIS COMPONENT MACHINERY MUST NOT BE PUT INTO SERVICE UNTIL THE MACHINERY INTO WHICH IT IS TO BE INCORPORATED HAS BEEN DECLARED IN CONFORMITY WITH THE PROVISIONS OF THE SUPPLY OF MACHINERY (SAFETY) REGULATIONS 1992/MACHINERY DIRECTIVE.</p> <p>FOR AND ON BEHALF OF NEWAGE INTERNATIONAL LIMITED</p> <p>NAME: LAWRENCE HAYDOCK POSITION: TECHNICAL DIRECTOR</p> <p>SIGNATURE:</p> <p>THIS COMPONENT MACHINERY CARRIES THE CE MARK FOR COMPLIANCE WITH THE STATUTORY REQUIREMENTS FOR THE IMPLEMENTATION OF THE FOLLOWING DIRECTIVES The EMC Directive 89/336/EEC WARNING! This Component Machinery shall not be used in the Residential, Commercial and Light Industrial Environment unless it conforms to the relevant standard (EN 50081 - 1) REFER TO FACTORY FOR DETAILS ii) The Low Voltage Directive 73/23/EEC as amended by 93/68/EEC</p>
--



ELECTROMAGNETIC COMPATIBILITY

Additional Information

European Union

Council Directive 89/336/EEC

For installations within the European Union, electrical products must meet the requirements of the above directive, and Markon ac generators are supplied on the basis that:

- They are to be used for power-generation or related function.
- They are to be applied in one of the following environments:
 - Portable (open construction - temporary site supply)
 - Portable (enclosed - temporary site supply)
 - Containerised (temporary or permanent site supply)
 - Ship-borne below decks (marine auxiliary power)
 - Commercial vehicle (road transport / refrigeration etc)
 - Rail transport (auxiliary power)
 - Industrial vehicle (earthmoving, cranes etc)
 - Fixed installation (industrial - factory / process plant)
 - Fixed installation (residential, commercial and light industrial - home / office / health)
 - Energy management (Combined heat and power and/or peak lopping)
 - Alternative energy schemes
- The standard generators are designed to meet the industrial emissions and immunity standards. Where the generating set is required to meet the residential, commercial and light industrial emissions and immunity standards then reference should be made to the factory.
- The installation earthing scheme involves connection of the generator frame to the site protective earth conductor using a minimum practical lead length.
- Maintenance and servicing with anything other than factory supplied or authorised parts will invalidate any Newage liability for EMC compliance.

CONTENTS

SECTION 1	INTRODUCTION	8
1.1	BL105 Generator	8
1.2	SL105 Generator	9
1.3	TL105 Generator	10
SECTION 2	APPLICATION	11
2.1	Standards	11
2.2	Airflow	11
2.3	Direction Of Rotation	11
2.4	Drive Arrangement	11
2.4.1	Road Vehicle Generators	11
2.5	Bearings	12
2.5.1	Road Vehicle Generators	12
2.6	Earthing	12
2.7	Loading	12
SECTION 3	INSTALLATION	13
3.1	Safety Warnings	13
3.2	Inspection	13
3.3	Coupling to Engine	14
3.4	Electrical Connections	14
3.5	Voltage Selection	14 -15
3.6	Voltage Adjustment For The SL105 - AVR MD1C	15
3.7	Stability	16-17
SECTION 4	SERVICE & MAINTENANCE	18
4.1	General	18
4.2	Insulation Resistance Check	19
4.3	Fault Finding	19-22
4.4	Residual Voltage/Field Flashing	23
4.5	Resistance Charts	24
SECTION 5	ASSEMBLY/DISMANTLING PROCEDURE	25
5.1	Assembling Generator to Engine	25
5.2	Dismantling Stator Frame Assembly	26
5.3	Withdrawing Rotor from Engine	26
5.4	Removal/Replacement of Capacitor - BL Models	26

CONTENTS

5.5	Removal/Replacement of Diode Varistor Assembly - BL Models	26-27
5.6	Removal/Replacement of AVR - SL Models	27
5.7	Removal/Replacement of AVR - TL Models	27
5.8	Removal/Replacement of Diode Bridge - SL Model	27
5.9	Removal/Replacement of Choke - SL Model	28
5.10	Removal/Replacement of Radio Interference Suppressor (RIS) -SL and TL Models	28
5.11	Removal/Replacement of Bearing	28
5.12	Removal/Replacement of Brushes/Brushbox Assembly – SL & TL Models	29
5.13	Torque Settings	29
SECTION 6	SPARES AND AFTER SALES SERVICE	30
6.1	Recommended Spares	30
6.2	After Sales Service	31
	BL105 Parts Identification - Single Bearing	32
	Typical BL105 Generator - Single Bearing	33
	SL105 Parts Identification	34
	Typical SL105 Generator	35
	BL105 Parts Identification - Two Bearing	36
	Typical BL105 Generator - Two Bearing	37
	TL105 Parts Identification	38
	Typical TL105 Generator	39
	Warranty Details	IBC

SECTION 1

INTRODUCTION

Models covered by this manual are designated as follows:-

BL105A	SL105A	TL105G
BL105B	SL105B	
BL105C	SL105C	
BL105E	SL105E	
BL105F	SL105F	
BL105G	SL105G	

1.1 BL105 GENERATOR

The BL105 is a self exciting brushless generator, designed to operate with single phase loads at or near a power factor of 1.0. The principle of operation is schematically represented in the diagram below. The auxiliary winding, in conjunction with the excitation capacitor, provides excitation by inducing current in the rotor (field) windings which is rectified to produce a direct current field. The main stator winding is designed for series/parallel connection to give a dual voltage output and no voltage adjustment is possible.

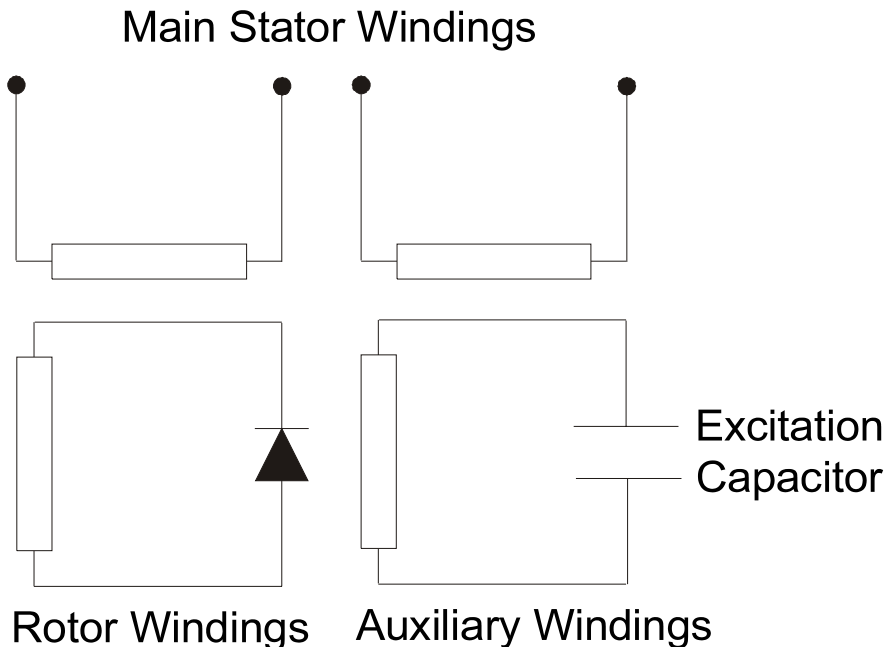

1.2 SL105 GENERATOR

The SL105 generator is of self-exciting, automatic voltage regulator (AVR) controlled, rotating field design. It is designed to operate with close regulation when supplying single phase loads. Primarily designed for loads at or near unity power factor, it has a capability of operation at 0.8 power factor.

The principle of operation is schematically represented in the diagram below. The auxiliary winding provides excitation power through a choke and rectifier into the rotating field via sliprings.

The AVR diverts excess excitation at low loads to maintain the main stator winding output voltage within close limits.

The main stator winding is designed for series/parallel connection to give a dual voltage output with voltage adjustment.

The SL105 generator may be supplied without a divertor AVR for specific applications. For these generators the instructions given in this manual for the SL105 generator apply, but references to the AVR or its control should be ignored.

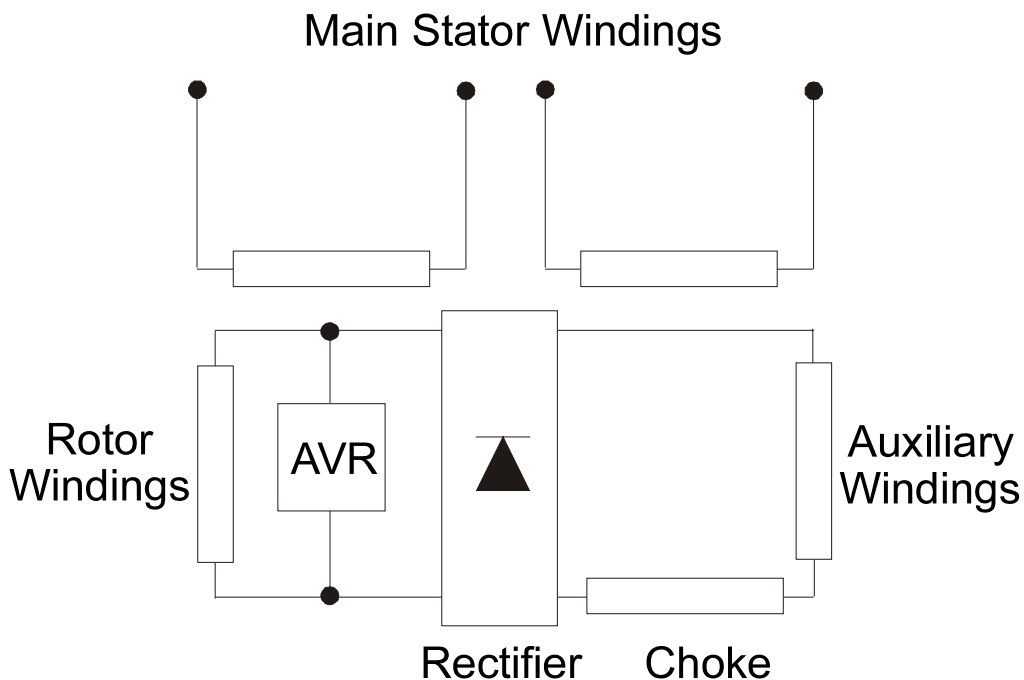

1.3 TL105 GENERATOR

The TL105 is a self-exciting, automatic voltage regulator (AVR) controlled rotating field three phase generator. It is designed to operate with close voltage regulation when supplying balanced and unbalanced loads at power factors between 0.8 and 1.0.

The principle of operation is schematically represented in the block diagram below.

The aux stator winding provides excitation power through the AVR which controls the level of excitation passed via the sliprings into the field winding (rotor).

The AVR senses the voltage output of the main stator winding and controls the excitation at varying loads to maintain the main stator winding output voltage within close limits.

Note: AVR tapping point varies depending upon generator output voltage, the AVR input voltage must be in the range of 100 - 120v.

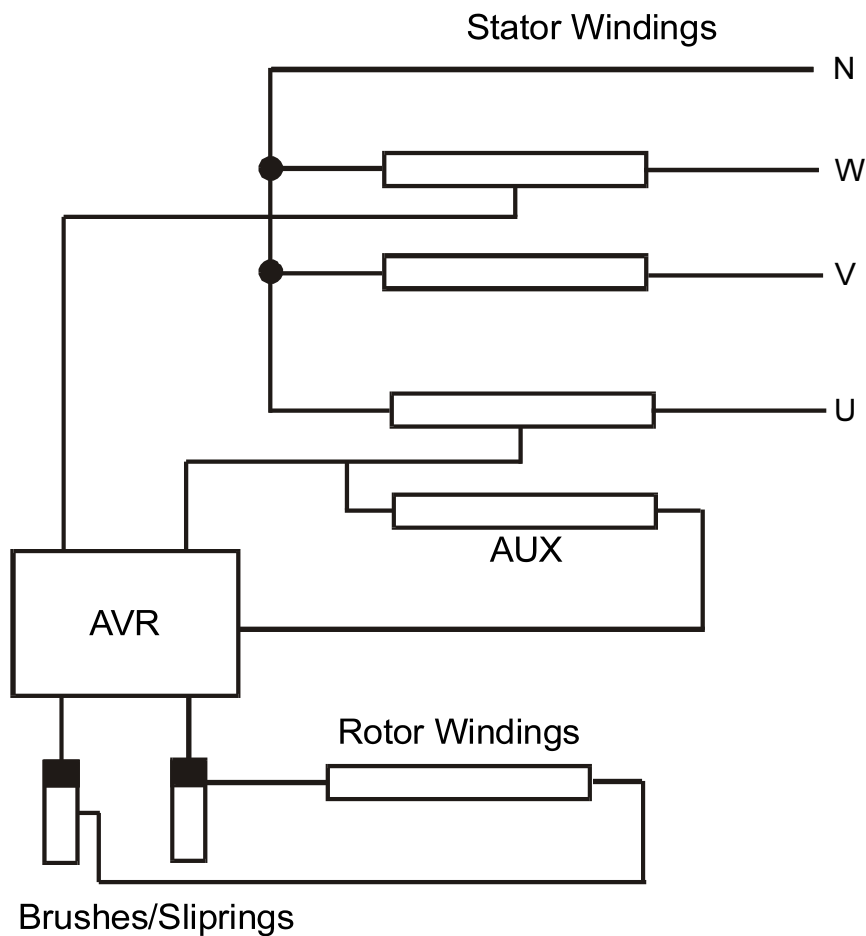

SECTION 2

APPLICATION

2.1 STANDARDS

The generator has been designed to comply with the requirements of most International Standards and is suitable for operation in an ambient temperature of 40°C maximum.

2.2 AIRFLOW

The generator should be positioned so that the cooling air may enter and leave the machine without restriction. Inadequate ventilation to the generator will lead to serious overheating and subsequent damage to windings.

2.3 DIRECTION OF ROTATION

The generator is suitable for either direction of rotation.

2.4 DRIVE ARRANGEMENT

All models are designed to suit engines having a drive shaft/crankcase mounting arrangement to SAE J609a Flange A Extension 5 (3/4" Taper) or Flange B Extension 6 (7/8" Taper) depending upon output kW.

Two bearing drive arrangements are available with a 22mm diameter 45.5mm long shaft extension.

The minimum pulley pitch diameter to be used for belt driven application is 118mm with a maximum side loading of 700N, to achieve full output and a reasonable bearing life. If smaller pulleys are required refer to factory for maximum side load and bearing life. Where single bearing to two bearing conversion parts have been supplied fitting instructions are provided with the kit.

2.4.1 ROAD VEHICLE GENERATORS

A special two bearing arrangement is used for this application to accommodate high bearing loadings and vibration. The standard 22mm diameter, 45.5mm long shaft extension is used.

The minimum pulley pitch diameter to be used is 118mm with a maximum side loading of 1000N.

2.5 BEARINGS

The bearing is preloaded and sealed for life and should require no further attention. Care must be taken to ensure that the anti-creep circlip is correctly located in the groove before mating with the end bell bearing housing, i.e. the bump on the circlip is in the deepest part of the groove.

On two bearing machines the drive end bearing is a standard ball bearing sealed for life.

2.5.1 ROAD VEHICLE GENERATORS

These generators are fitted with larger bearings than standard. The drive end bearing is clamped in the drive end bracket and the non drive end bearing is fitted in a steel housing with an 'O' ring to prevent turning.

2.6 EARTHING

The generator is manufactured and delivered with the stator windings completely isolated from the frame; a suitable earth terminal mounting point is provided on the bearing support for bonding to the generating set frame.

Access to the earth terminal is gained by removal of the end cover.

2.7 LOADING

The generators are suitable for supplying, continuously, most types of load with a total load current not exceeding the current quoted on the nameplate. Two points should be noted however:

1. Engine Power.

The generator set output may be limited by the horsepower rating of the engine. As a guide the engine has to supply approximately two horsepower for each 1000 watts (1kW) of electrical load. Refer to factory for specific generator efficiency.



2. Electric Motor Loads.

The current taken by a motor on full load is shown on its nameplate, but it will be several times this value at the instant of starting even when there is no load on the motor. The actual value depends on the type of motor and the starting current should be checked before attempting to decide the size of generator required.

When starting a motor the total current including any other load should not exceed twice the full-load current of the generator on BL105 models. The total current should not exceed 1.5 times the full-load current on SL105 and TL105 models.

SECTION 3

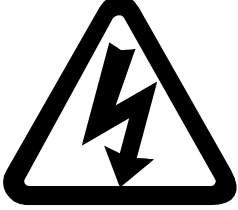
INSTALLATION

3.1 SAFETY WARNINGS	 REFER TO SERVICE MANUAL BEFORE REMOVING COVERS ABNEHMEN DER ABDECKUNGEN NUR GEMAESS HANDBUCH ANWEISUNG LEGGERE IL MANUALE DI ASSISTENZA PREMA DI RIMUOVERE I COPERCHI CONSULTAR MANUAL ANTES DE RETIRAR TAPAS VOIR MANUEL DE SERVICE AVANT D'ENLEVER LES COUVERCLES راجع كتيب الصيانة قبل نزع الأغطية
REFER TO LOCAL REGULATIONS TO ENSURE THAT THE CORRECT EARTHING PROCEDURE HAS BEEN FOLLOWED  WARNING !	
<p>The generator is supplied as a component part for installation on a generating set and it is the responsibility of the generating set builder to fit the safety warning label, illustrated right, which is supplied packaged with this manual. The label should be attached to the generator in a position where it is clearly visible on the generating set.</p> <p>3.2 INSPECTION</p> <p>When the equipment is received all details, especially the Serial Number of the generator, should be checked against the Advice Note. Carefully remove all dust and packing materials. In the event of any part being damaged or missing, this should be reported at once to the manufacturer and the transport company. Always quote the Serial Number on correspondence with the manufacturer.</p>	

When nameplates are supplied packaged with the machine, but not fitted, it is the responsibility of the installer to fit the nameplate to the generator.

3.3 COUPLING TO ENGINE

Refer to Assembly/Dismantling Procedure. SECTION 5.

3.4 ELECTRICAL CONNECTIONS

The generators are supplied from the factory with flying leads from the main stator windings. The BL105 & SL105 may be permanently connected or switched in the generator set outlet box to obtain the required output voltage(s). The installer must provide necessary overload protection. The windings are not bonded to the machine frame and it is the responsibility of the installer to provide suitable bonding to earth. Reference should be made to relevant site or safety regulations. Note that the point of earthing the stator winding is at the discretion of the installer.

Normally a 230 volt 2 wire output will be earthed at one end giving a maximum of 230 volts to earth (Or 115 volts in parallel mode).

A 110 volt 2 wire output will normally be earthed at the centre tap (series connection point) giving a maximum of 55 volts to earth.

The standard TL105 arrangement provides six line output leads for connection in Star or Delta configuration.

Reference should be made to relevant site or safety regulations.

3.5 VOLTAGE SELECTION

1. Dual Voltage Output

The main stator windings are in two sections which may be connected in series or parallel to give a choice of output voltage. For example, series connection gives 230V, parallel connection gives 115V.

This is illustrated below. Each winding section is capable of carrying the same current I . When the windings are connected in series the maximum load current is I , but when the windings are connected in parallel the maximum current is $2 \times I$.

Example:

A 2.5kVA generator when connected in series for 230V operation has a capacity of 10.9A; when connected in parallel for 115V it has a capacity of 21.7A.

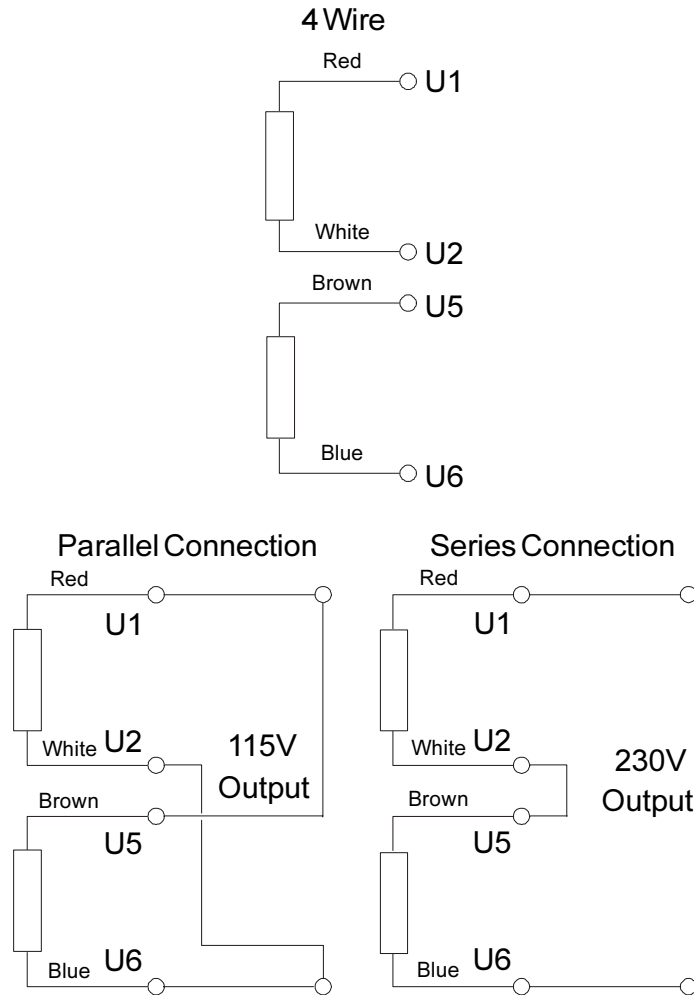

2. 110V CTE Output (BL105 range only).

The main stator windings are in two sections which should be connected in series to give 110V output, with the centre tap taken from the series connection point.

3.6 VOLTAGE ADJUSTMENT FOR THE SL105 - AVR MD1C

The voltage is set during manufacture to give the mid-voltage of the range of voltages shown on the nameplate, ie: a generator whose nameplate is marked 220-240 / 110-120V will be set to give 230 volts with the output windings connected in series and 115 volts when connected in parallel.

The voltage may be reset to any value within the nameplate range. To RAISE the voltage turn the volts adjust potentiometer VR1 CLOCKWISE and to LOWER the voltage turn the potentiometer ANTI-CLOCKWISE.

The volts adjust potentiometer is the one at the bottom of the board.

3.7 STABILITY

This control should not normally require adjustment having been set during manufacture, but should the output voltage fluctuate with a steady load connected, this may be improved by turning the potentiometer anti-clockwise which will increase the damping effect.

Note

1. Do not use undue force when turning the potentiometers - they can be damaged by attempting to adjust beyond the internal stops.
2. When making either adjustment the speed must be correct.

TL Models

TL generators have a voltage range of approximately 5%, e.g. 380 - 415 volts.

Voltage adjustment is effected by adjustment of the 'SET VOLTS' control potentiometer located on the AVR. Access to the AVR is gained by removal of the cover of the black, side mounted box.

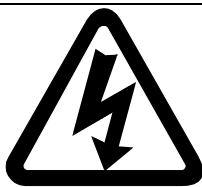

Danger !

Removal of the air intake cover allows access to LIVE parts. Only persons qualified to carry out electrical servicing should carry out adjustments.

TL generators may be supplied with a 12 lead winding suitable for series/parallel connection.

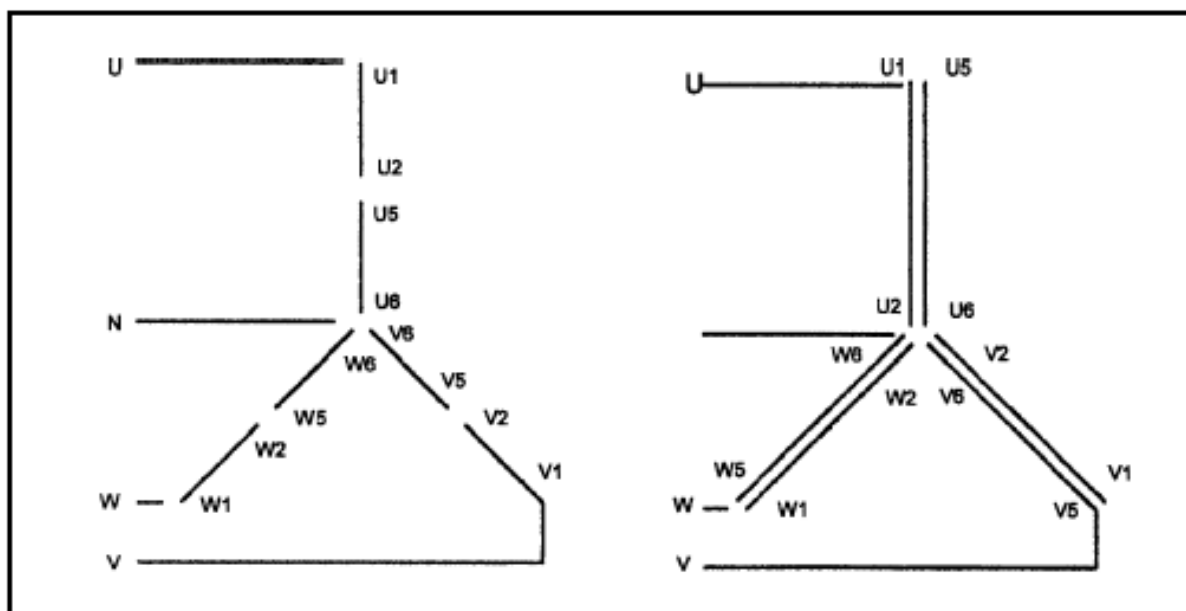

The installer must provide suitable terminations or switching arrangements to provide a safe reconnection means.

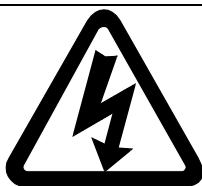

Danger !

Air gap adjustment should be made in small increments, and should only be carried out by personnel qualified to perform electrical service.

SECTION 4

SERVICE & MAINTENANCE



Warning !

The following procedures present hazards which can result in personal injury or death. Only persons qualified to carry out electrical and mechanical servicing should undertake this work.

4.1 GENERAL

The BL model generator is fitted with sealed for life bearings and requires no regular maintenance.

The SL and TL models similarly require no regular mechanical maintenance. They are, however, fitted with sliprings and brushgear which require regular attention.

Inspect brushes and sliprings at 500 hour intervals. Replace brushes when they are worn to a depth of 8mm. The new brush should be bedded using a medium grade abrasive cloth. If the sliprings are pitted or badly marked the rotor should be removed and the sliprings lightly skimmed.

The generator must periodically be inspected and any accumulation of dirt or oil must be removed. Air inlet and outlet openings must be kept unobstructed.

For BL, SL and TL models it is recommended that:-

- 1) After storage or long periods of standing idle the condition of windings should be checked. Refer to 'Insulation Resistance Check' subsection 4.2,

and

- 2) During generating set overhaul, the bearing is replaced. Refer to Assembly/Dismantling Procedure, Section 5.

4.2 INSULATION RESISTANCE CHECK

If the equipment has been stored or allowed to get damp the insulation resistance of the windings should be checked.

On BL models before carrying out this test disconnect the capacitor and any earthed connections.

On SL models disconnect AVR, rectifier, RI suppressor [17] and any earthed connections.

On TL models disconnect AVR and RI suppressor [17] and any earthed connections.

The check should be carried out on the stator winding between each winding group and the generator frame, and between the rotor winding and rotor core using a 500 volt Megger or similar instrument. The resistance value obtained should be at least one megohm. If the resistance is less than one megohm the windings should be dried out in a warm atmosphere. The resistance values should be rechecked every 30 minutes until this value is obtained.

4.3 FAULT FINDING

Should a fault develop during operation it is best identified by carrying out the checks identified in the following fault finding guides.

Refer to Assembly / Dismantling section when attempting to replace components.

Before proceeding always check security of all connections, especially those to control equipment and / or AVR.

On SL and TL models remove air intake cover and check condition of the sliprings, the freedom of movement of brushes, brush spring tension and amount of brushwear. Brushes should not be less than 8mm long.

BL MODEL - FAULT FINDING GUIDE

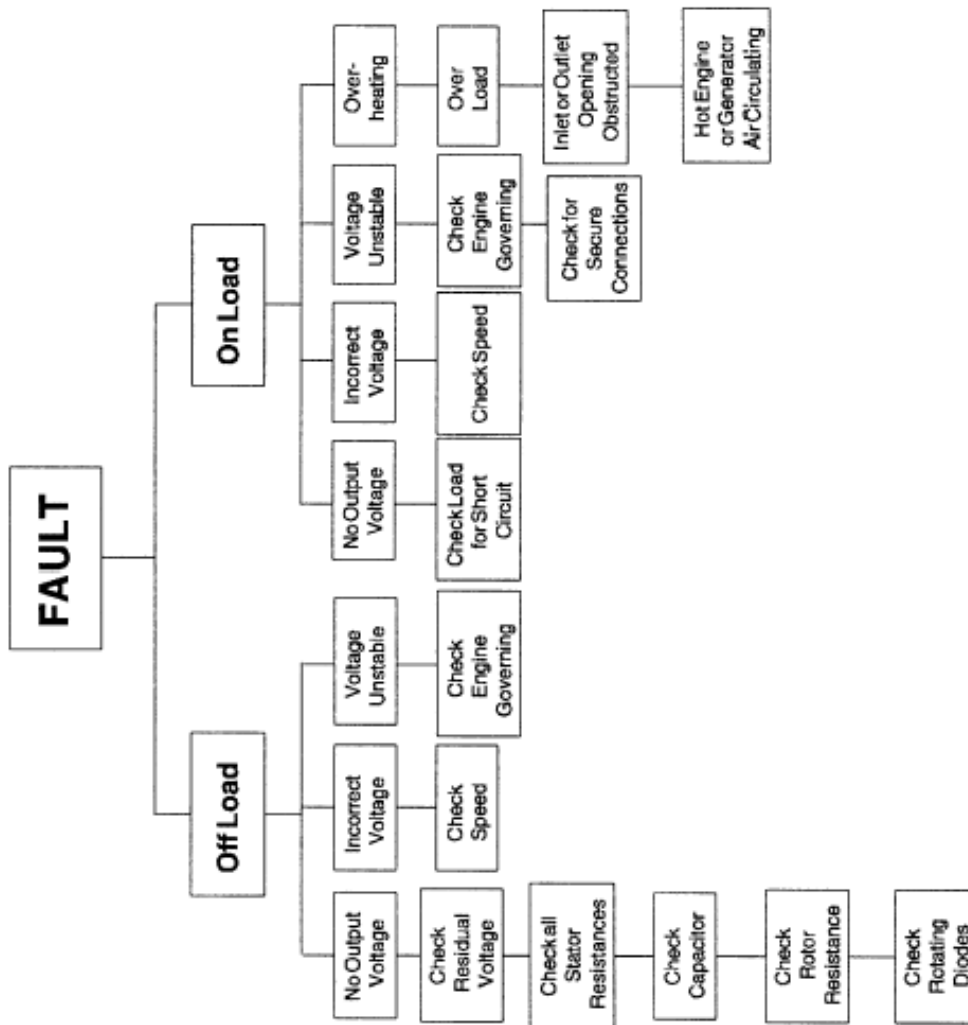

SL MODEL - FAULT FINDING GUIDE

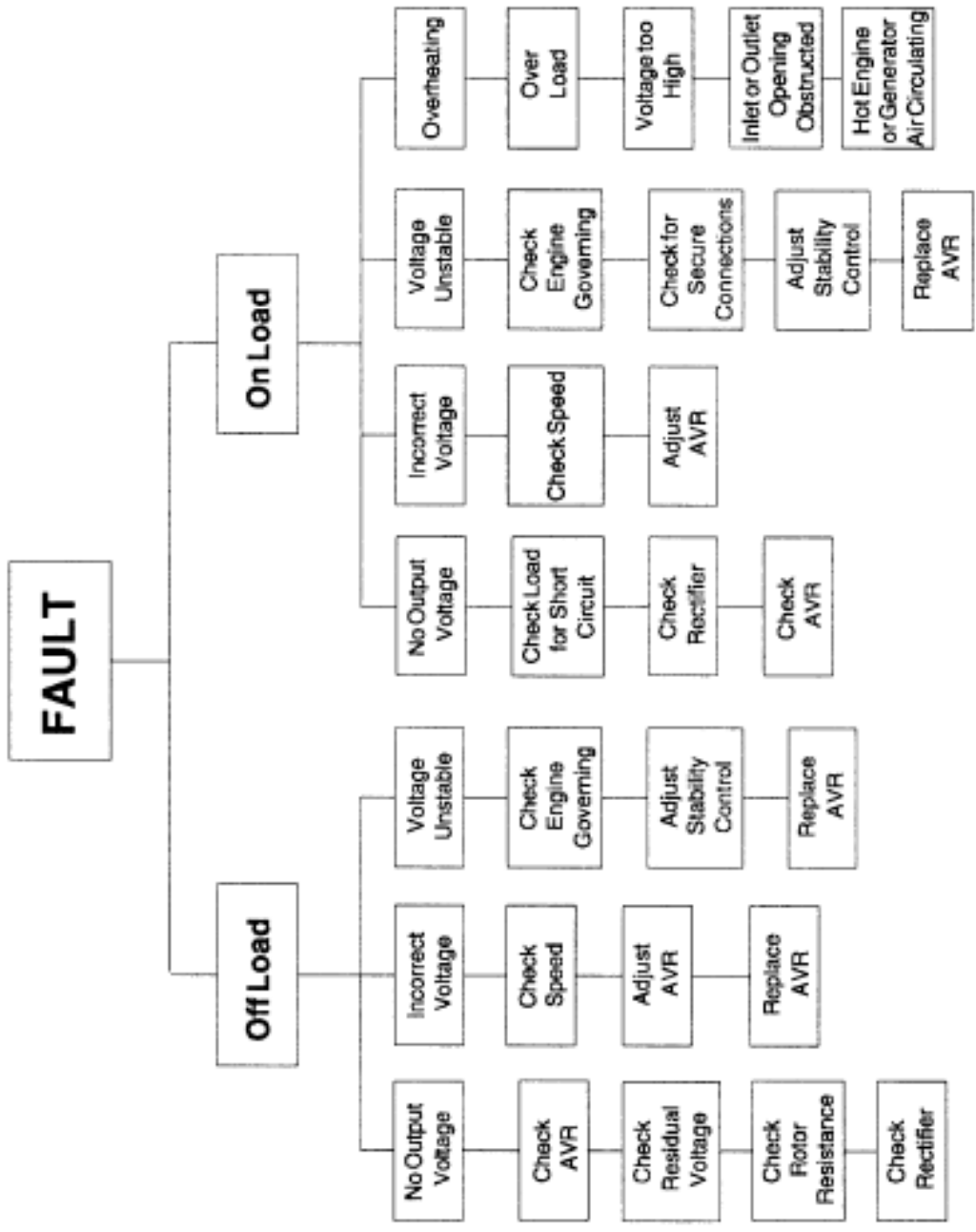

TL MODEL - FAULT FINDING GUIDE

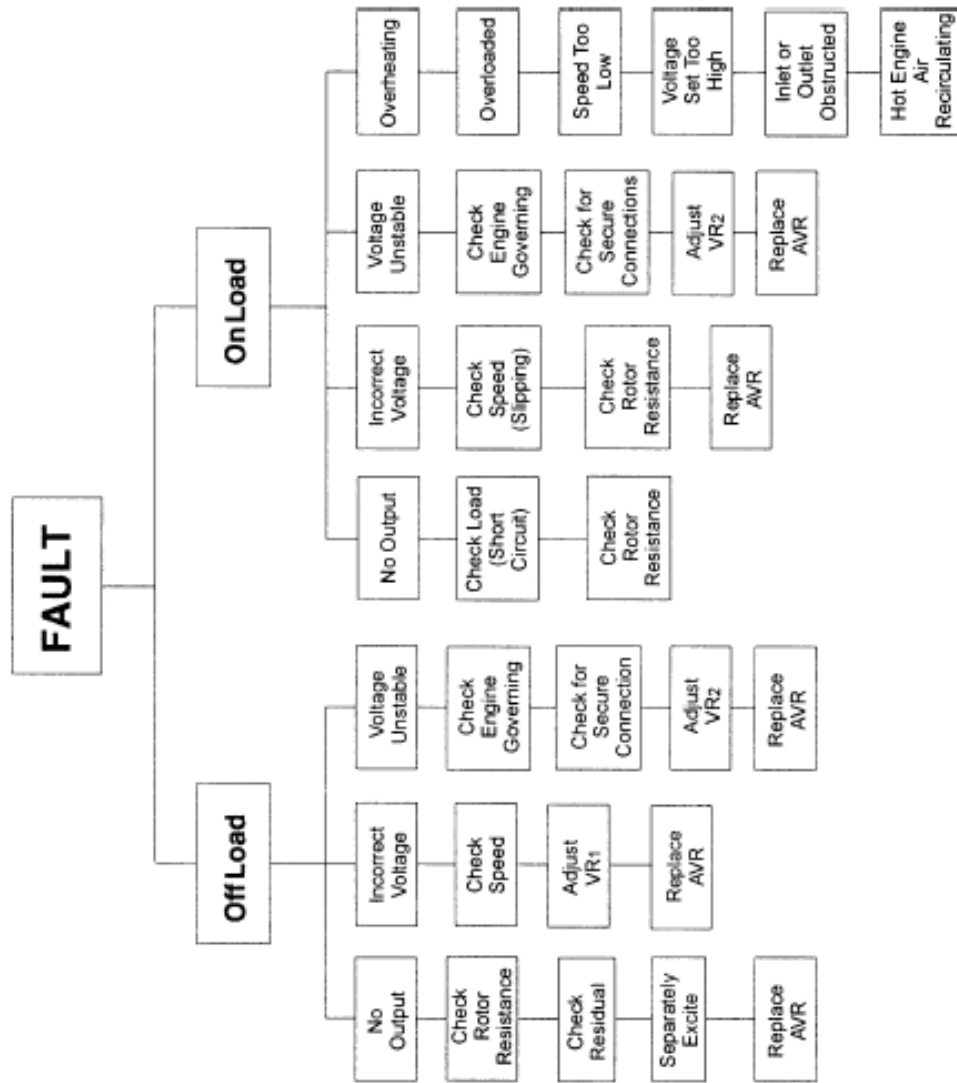

4.4 RESIDUAL VOLTAGE/FIELD FLASHING

If the rotor has been removed, the generator stored for a considerable time or the rotor (field) connections reversed during servicing, the residual magnetism may have been destroyed.

To check residual voltage, remove the end cover for access.

Remove capacitor leads (BL Model), Z2 from the rectifier assembly (SL Model), leads F1 -F2 from brush holders (TL Model).

Run the generator at normal no-load speed. Measure the voltage as indicated below:

Model BL105 across output leads U1 ó U2 Voltage 1.5 (min)
SL 105 across output leads U1 ó U2 Voltage 1.5 (min)
TL 105 across AVR terminals 7 - Z2 3.5 (min)

BL Model

Reconnect capacitor leads to original position. Run generator at normal no-load speed. A 12 volt battery should then be instantaneously flashed (that is connected for only one second) across the capacitor. The auxiliary leads must still be connected to the capacitor. The output voltage should then build up to the normal no-load level.

SL and TL Models

Reconnect lead Z2 to rectifier assembly and disconnect leads F1 - F2 (SL Model only). Run generator at normal no-load speed and apply a 12 volt supply, from the battery, to the brush -holder for about 3 seconds. Ensure the positive lead is applied to the brush holder nearest the bearing housing.

The output voltage of the generator, with the 12 volt supply connected, should be approximately normal voltage. Stop the generator and reconnect leads F1 - F2.

Important ! Ensure the battery leads are connected to the brush holder with the correct polarity, and leads F1 - F2 are isolated from each other and earth.

Check windings for continuity and resistance values to the following table .
(Subsection 4.5).

4.5 RESISTANCE CHARTS

All figures are approximate values in ohms.

Main stator values are based on 50Hz windings.

60Hz windings at listed voltages will have values of 0.7 times the 50Hz value.

MODEL	VOLTAGE	ROTOR	MAIN STATOR	AUXILLIARY
			PER SECTION	WINDING
BL105A		7.90	1.00	1.29
BL105B		8.12	0.80	1.00
BL105C	115 / 230	8.60	0.64	1.10
BL105E		9.57	0.41	1.07
BL105F		10.05	0.31	0.88
BL105G		10.53	0.28	0.74
BL105A		7.90	0.21	1.29
BL105B		8.12	0.18	1.04
BL105C	55 / 0 / 55	8.60	0.14	1.10
BL105E		9.57	0.098	1.07
BL105F		10.05	0.074	0.85
BL105G		10.53	0.064	0.74
SL105A		11.10	1.32	4.24
SL105B		11.50	0.86	4.17
SL105C	115 / 230	12.20	0.66	3.18
SL105E		10.80	0.43	2.16
SL105F		11.30	0.36	1.94
SL105G		11.90	0.28	1.77
SL105A		11.10	0.29	4.24
SL105B		11.50	0.21	4.17
SL105C	55 / 0 / 55	12.20	0.16	3.18
SL105E		10.80	0.11	2.16
SL105F		11.30	0.09	1.94
SL105G		11.90	0.065	1.77
TL105G	380 / 415	11.90	1.50	4.70
TL105G	220 / 240	11.90	0.49	4.70
TL105G	208 / 240	11.90	0.38	4.70



Warning !

**Replace all guards and protective covers after servicing.
Failure to do so may result in operator personal injury.**

SECTION 5

ASSEMBLY/DISMANTLING PROCEDURE

Component identification numbers refer to those shown in Generator Parts Identification (Pages 35, 37, 39, 41, 43 and 45).

5.1 ASSEMBLING GENERATOR TO ENGINE

Apply LOCTITE 'THREADLOCK' or equivalent to one end of the shaft securing stud [1]. Fit this end of the shaft securing stud [1] into the engine shaft, ensuring the full length of thread is engaged.

Fit appropriate engine adaptor plate and fit studs supplied into the generator side of the adaptor plate and tighten.

Remove end cover fixing screws [2] and end cover [3].

Remove transit bolt from shaft end and discard both bolt and large washer.

Important ! On SL and TL models care must be taken to avoid damage to the carbon brushes by excessive axial movement of the rotor. Lift brushes if in doubt.

Offer stator frame assembly [4] complete with rotor assembly up to the engine, feeding rotor over securing stud and frame on to the adaptor studs. Tap frame over the adaptor spigot.

Fit nuts and washers securing the frame to the adaptor studs and tighten.

Fit the 5/16" UNF SELF LOCKING nut (Shaft Securing Nut) [5] to the shaft securing stud [1] and tighten.

Replace end cover [3].

Secure stator frame assembly to the bedplate foot fixing(s). Where the stator frame assembly is rigidly mounted to the bedplate, shims must be fitted to ensure accurate alignment.

Refer to subsection 5.13 for torque settings.

5.2 DISMANTLING STATOR FRAME ASSEMBLY

Important ! On SL and TL models remove end cover fixing screws [2] and end cover [3] and lift brushes [12] (part of brushbox assembly).

Remove nuts securing frame to adaptor studs.

Remove feet fixing bolts (or nuts).

Tap frame away from the engine to release the adaptor spigot. Withdraw stator frame assembly over the rotor.

5.3 WITHDRAWING ROTOR FROM ENGINE

Remove the shaft securing nut [5].

Release rotor from engine taper shaft by supporting rotor in one hand and with a hide / soft faced mallet striking firmly on a pole face.

Important ! Do not use the fan [6] to prevent the rotor turning when releasing the shaft securing nut.

5.4 REMOVAL/REPLACEMENT OF CAPACITOR - BL MODELS

Remove end cover fixing screws [2] and end cover [3] and disconnect capacitor leads. Remove capacitor fixing nut [11] and cut nylon tie support [12]. Remove capacitor [13].

Replacement is a reversal of removal.

5.5 REMOVAL/REPLACEMENT OF DIODE VARISTOR ASSEMBLY - BL MODELS

Important ! Take careful note of connections and positions of the solder tags before carrying out the following procedure. Incorrect polarity of the diode varistor assembly will destroy residual magnetism.

Removal / replacement of diode varistor assembly and / or varistors is most easily carried out by removing end cover fixing screw [2] and end cover [3].

Support the rotor weight with a sling or block between the rotor and bedplate. Unsolder leads from diode pin [14], and unscrew diode stud. If the varistors [15] are to be replaced, unsolder varistor lead from solder tag [16] on the diode stud.

Prise out the silicone sealant from the recess(es) in the diode carrier [17], and remove the varistor(s) [15].

Fit new diode(s), placing solder tags on the diode stud(s) and tighten to diode base with a nut before feeding through the diode carrier and securing with a second nut. Insert new varistor(s), leads first, and push varistor(s) body well down into the varistor carrier [17] recess(es). Solder leads to diode pin and the solder tag on the diode stud. Reseal with silicone sealant.

Important ! Nut threads should be treated with loctite 242, nuts to be torque tightened to 1.6Nm.

5.6 REMOVAL / REPLACEMENT OF AVR - SL MODELS

Remove end cover fixing screws [2] and end cover [3].

Disconnect the four leads (three black and one grey) from the four spade terminals on the right hand side of the AVR, taking note that the grey lead is always connected to the terminal marked F1.

Remove the three AVR fixing screws [13] and remove AVR [14].

Replacement is a reversal of removal. Ensure that the leads to the AVR are correctly replaced and the grey lead is connected to terminal F1.

If grey (F1) and black (F2) leads are reversed it will be necessary to flash the field when restarting. Refer to subsection 4.4.

5.7 REMOVAL/REPLACEMENT OF AVR - TL MODELS

Remove the 4 fixing screws and pull the lid of the box containing AVR away. Disconnect all AVR leads.

Remove the 4 AVR fasteners.

Lift away AVR.

Replacement is a reversal of removal. Ensure that AVR leads are correctly replaced.

5.8 REMOVAL/REPLACEMENT OF DIODE BRIDGE – SL MODELS

Important ! Note positions of leads on the assembly before removal.

Remove end cover fixing screws [2] and end cover [3].

Remove leads from diode bridge [16]. Remove diode bridge fixing screw [22] and remove diode bridge.

Replacement is a reversal of removal.

5.9 REMOVAL/REPLACEMENT OF CHOKE - SL MODELS

Remove end cover fixing screws [2] and end cover [3].

Remove diode bridge fixing screws [22]. Lift away choke and remove connecting leads. Remove choke [15].

Replacement is a reversal of removal.

5.10 REMOVAL/REPLACEMENT OF RADIO INTERFERENCE SUPPRESSOR (RIS) - SL and TL Models when applicable

Remove connecting leads.

Remove RIS fixing screw [19] and remove RIS [17]. Replacement is a reversal of removal.

Important ! Ensure that the RIS spacer [20] is fitted between the RIS and frame.

5.11 REMOVAL / REPLACEMENT OF BEARING

With the rotor withdrawn, use a standard bearing puller to remove the bearing from the shaft. Place new bearing squarely on the shaft end with anti-creep circlip groove inboard and drift into place using a suitably sized soft tubular drift on the bearing inner race.

Care must be taken to ensure that the anti-creep circlip is correctly located in the groove before mating with the bearing housing, i.e. the bump on the circlip is in the deepest part of the groove.

Refit the rotor assembly into the stator frame assembly taking care to avoid damaging wound components. Locate the bearing in the housing and tap into position.

Important ! On SL and TL Models ensure brushes are lifted before attempting to refit the rotor assembly into the stator frame assembly.

Assemble generator to engine. Refer to subsection 5.1.

5.12 REMOVAL/REPLACEMENT OF BRUSHES/BRUSHBOX ASSEMBLY - SL & TL MODELS

Remove end cover fixing screws [2] and end cover [3].

On SL models remove AVR [14]. Refer to subsections 5.6 and 5.7.

Remove fixing screw [21] and lift away brushbox assembly.

Replacement is a reversal of removal.

On SL models refit AVR as detailed in subsections 5.6 and 5.7.

If brushes only are to be changed remove brush terminal plate and withdraw springs and brushes. New brushes must be bedded using a medium grade abrasive cloth.

5.13 TORQUE SETTINGS

- Adaptor to engine - Refer to engine manufacturer.
- Adaptor to frame - 5.4Nm (0.55 kgf.m)
- Shaft securing nut - 20.4Nm (2.1 kgf.m)

Caution ! After servicing ensure all protective guards and access covers are fitted. Failure to do so can result in operator injury.

5.14 ROTOR MOUNTING TO THE ENGINE

For transit and storage purposes rotor coupling areas (taper part) have been coated with a rust preventive. This **MUST BE** removed before assembly to engine.

A practical method for removal of this coating is to clean the mating surface areas with a de-greasing agent based on a petroleum solvent.

Caution 1 !	Care should be taken not to allow any cleaning agent to come into prolonged contact with skin.
--------------------	---

SECTION 6

SPARES AND AFTER SALES SERVICE

6.1 RECOMMENDED SPARES

Service parts are conveniently packaged for easy identification.

We recommend the following for service and maintenance. In critical applications a set of these service spares should be held with the generator.

Description	Part No.	Quantity
BL105 Models		
1. Capacitor	009-092 40mfd	1
2. NDE Bearing	014-040	1
3. NDE Bearing - R.V.G.	014-041	1
4. DE Bearing - 2 Bearing	014-003	1
5. DE Bearing - R.V.G.	014-042	1
6. Diode Varistor Assembly	B105Z-11001 or 240-10335 (Snubber) or 240-10336 (PCB)	1

Note: R.V.G. refers to Road Vehicle Generator.

SL Models

1. AVR MD1C	036-245	1
2. Diode Bridge	002-058	1
3. NDE Bearing	014-040	1
4. DE Bearing - 2 Bearing	014-003	1
5. Brushbox (including brushes)	011-008	1
6. Carbon Brush with spring	010-026	2

TL105 Models

1. AVR E000-24105 1		
2. Brush Box (including brushes)	011-008	1
3. Carbon Brush with spring	010-026	2
4. NDE Bearing	014-040	1
5. DE Bearing	014-003	1

When ordering spare parts the machine serial number and type should be quoted, together with the part description. The serial number is on the side of the generator. Orders and enquiries for parts should be addressed to:

Markon Sawafuji Ltd
3 Lands End Way
Oakham
Rutland
LE15 6RB
ENGLAND

Telephone: 44 (0) 1572 723811

Fax: 44 (0) 1572 756856

Or any of our subsidiary companies listed on the back cover.

6.2 AFTER SALES SERVICE

A full technical advice and on-site service facility is available from our Service Department in Oakham or through our Subsidiary Companies. Call for quotation.

BL105 PARTS IDENTIFICATION - SINGLE BEARING

Plate Ref	Description	Part Numbers
1	SHAFT SECURING STUD	Various
2	END COVER FIXING SCREWS	005-04053
3	END COVER (PLASTIC)	14-116 / 1
3	END COVER (STEEL)	240-20344
4	STATOR FRAME ASSEMBLY	Various
5	SHAFT SECURING NUT	018-001
6	FAN	240-10213
7	WOUND ROTOR ASSEMBLY	Various
8	BEARING	014-040
9	AIR BAFFLE	240-10127
10	INSULATING BUSH	016-016
11	CAPACITOR FIXING NUT	With Capacitor
12	CAPACITOR SUPPORT BRACKET	240-10120
13	CAPACITOR (40uf)	009-092
14	DIODE (Forward) 800v	002-022
14a	DIODE (Reverse) 800v	002-023
14b	DIODE (Single Diode Type) 1200v	073-50042
15	VARISTOR	073-08160
16	SOLDER TAG	020-131
17	DIODE / VARISTOR CARRIER HUB	20-205 / 1
18	DIODE / VARISTOR HUB ASSEMBLY (2 Diode Type)	B105Z-11001
18a	DIODE / VARISTOR HUB ASSEMBLY (1Diode Type)	240-10335
18b	DIODE / VARISTOR HUB ASSEMBLY (PCB Type)	240-10336
19	CAPACITOR BRACKET FIXING SCREW	005-04084

TYPICAL BL105 GENERATOR – SINGLE BEARING

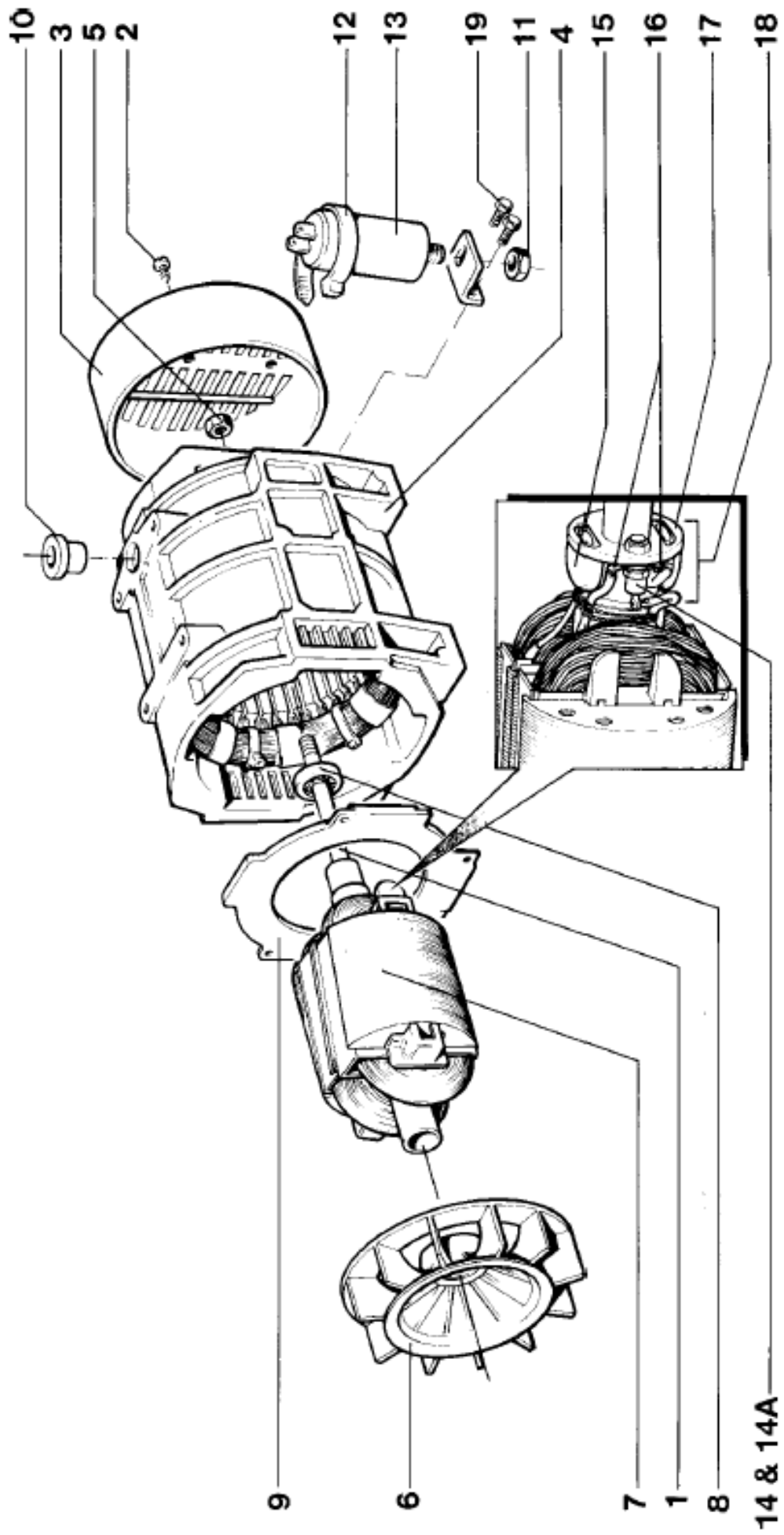

SL105 PARTS IDENTIFICATION

Plate Ref	Description	Part Numbers
1	SHAFT SECURING STUD	Various
2	END COVER FIXING SCREWS	005-04053
3	END COVER (PLASTIC)	14-116 / 1
3	END COVER (STEEL)	240-20344
4	STATOR FRAME ASSEMBLY	Various
5	SHAFT SECURING NUT	018-001
6	FAN	240-10213
7	WOUND ROTOR ASSEMBLY	Various
8	BEARING	014-040
9	AIR BAFFLE	240-10127
10	INSULATING BUSH	016-016
11	SLIPRINGS	013-001
12	BRUSHBOX ASSEMBLY	011-008
13	AVR FIXING SCREWS	504-163
14	AUTOMATIC VOLTAGE REGULATOR (AVR)	036-245
15	CHOKER	240-20346
16	DIODE BRIDGE	002-058
17	RADIO INTERFERENCE SUPPRESSOR (RIS)	036-115
18	BRUSHBOX MOUNTING PLATE	240-10126
19	RIS FIXING SCREW	005-04076
20	RIS INSULATING SPACER	240-10137
21	BRUSHBOX FIXING SCREW	016-40613
22	DIODE BRIDGE FIXING SCREW	005-04076

TYPICAL SL105 GENERATOR

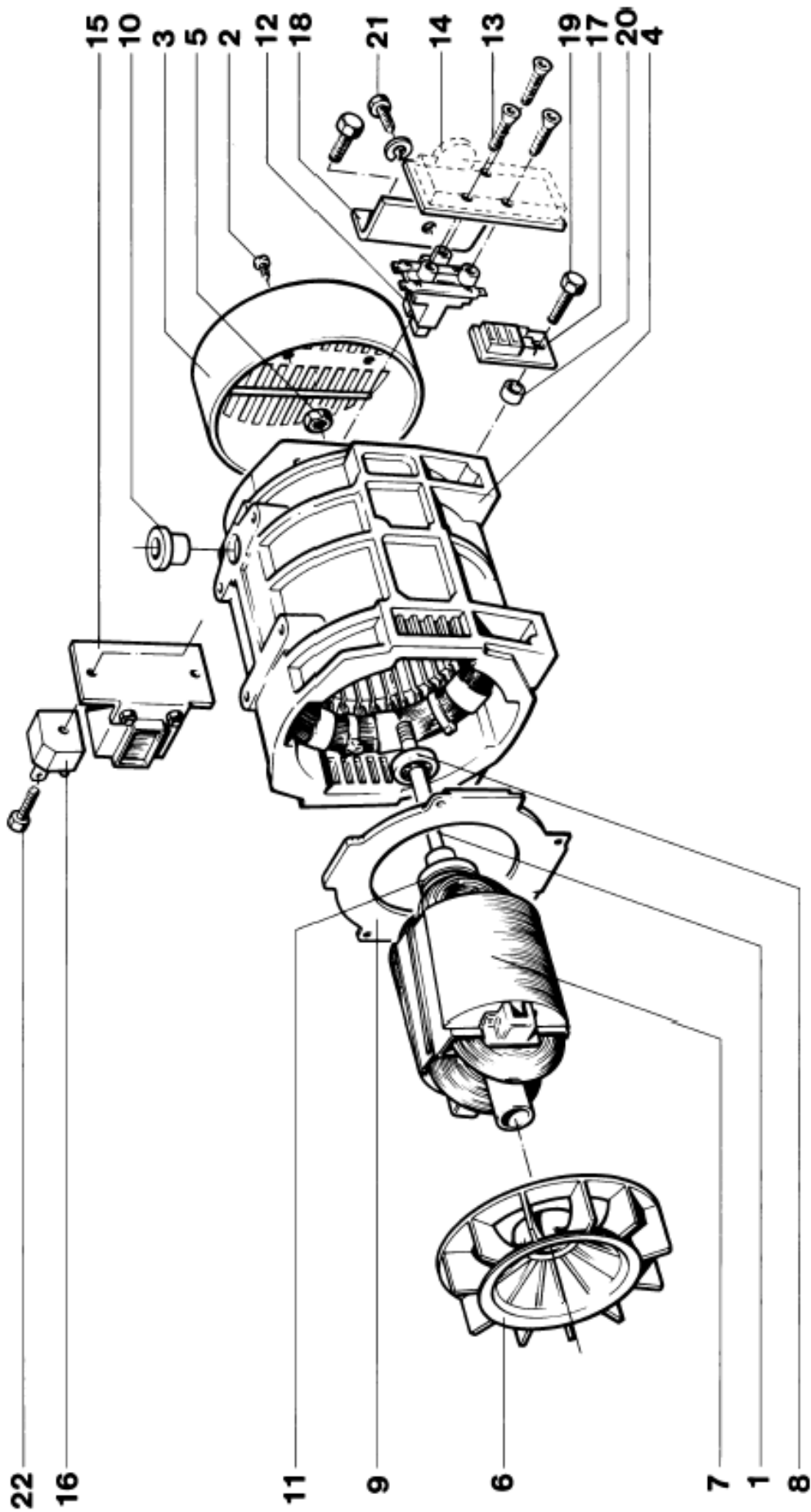

BL105 PARTS IDENTIFICATION – TWO BEARING

1	SHAFT SECURING STUD*	240-20618 or 240-20624
2	END COVER FIXING SCREWS	005-04053
3	END COVER	14-116 / 1 or 240-20344
4	STATOR FRAME ASSEMBLY	Various
5	SHAFT SECURING NUT*	018-001
6	FAN	240-10213
7	WOUND ROTOR ASSEMBLY	Various
8	BEARING – NON DRIVE END	014-040* / 014-041**
9	AIR BAFFLE	240-10127
10	INSULATING BUSH	016-016
11	CAPACITOR FIXING NUT	With Capacitor
12	CAPACITOR SUPPORT	240-10120
13	CAPACITOR (40uf)	009-092
14	DIODE	(See Single Bearing parts list)
15	VARISTOR	073-08160
16	SOLDER TAG	020-131
17	DIODE / VARISTOR CARRIER HUB	20-205 / 1
18	DIODE / VARISTOR HUB ASSEMBLY	(See Single Bearing parts list)
19	STUB SHAFT*	05-416 / 1 or 05-417 / 1
20	BEARING RETAINING SCREW	016-40717
21	D.E.BRACKET	Various
22	BEARING RETAINING WASHER*	501-016
23	BEARING – DRIVE END	014-003* / 014-042**
24	BEARING RETAINING WASHERS**	501-057
25	'O' RING**	019-014
26	BEARING HOUSING**	240-10154
27	D.E.BRACKET**	Various

*CONVERSION KIT ONLY

** ROAD VEHICLE GENERATORS ONLY

TYPICAL BL105 GENERATOR - TWO BEARING

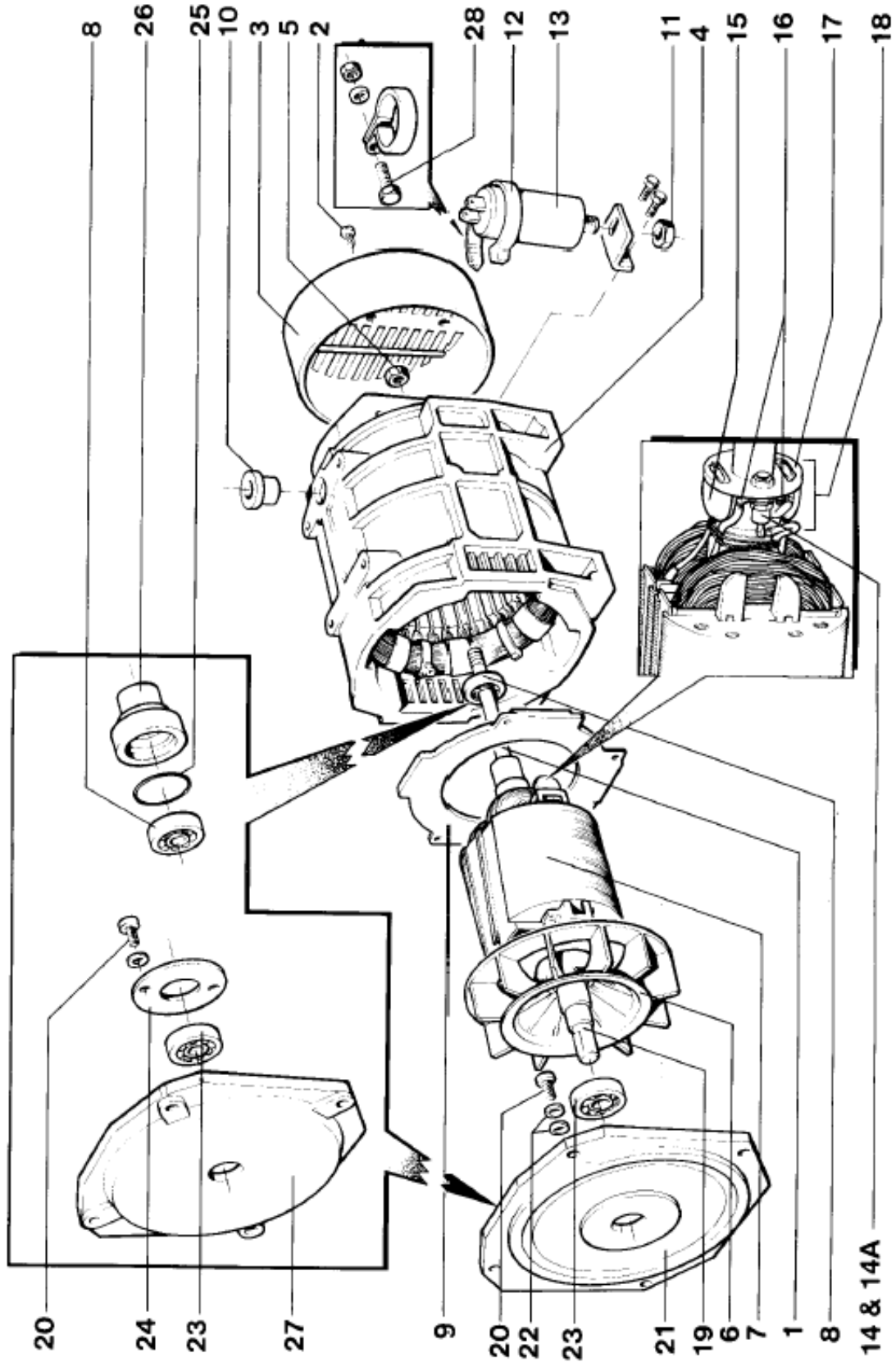

TL105 PARTS IDENTIFICATION

Plate Ref	Description	Part Number
1	SHAFT SECURING STUD	Various
2	END COVER FIXING SCREWS	005-04053
3	END COVER (PLASTIC)	14-116 / 1
3A	END COVER (STEEL)	240-20344
4	STATOR FRAME ASSEMBLY	Various
5	SHAFT SECURING NUT	018-001
6	FAN	240-10213
7	WOUND ROTOR ASSEMBLY	SL105G-391
8	BEARING	014-040
9	AIR BAFFLE	240-10127
10	INSULATING BUSH	016-016
11	SLIPRINGS	013-001
12	BRUSHBOX ASSEMBLY	011-008
13 / 14	AVR FIXING SCREW	TBA
15	AVR HOUSING	240-20347
16	AVR	E000-24105
17	RADIO INTERFERENCE SUPPRESSOR (RIS)	036-115
18	BRUSHBOX MOUNTING PLATE	240-10126
19	RIS FIXING SCREW	018-062
20	RIS INSULATING SPACER	240-10137
21	BRUSHBOX ASSEMBLY FIXING SCREW	504-115

TYPICAL TL105 GENERATOR

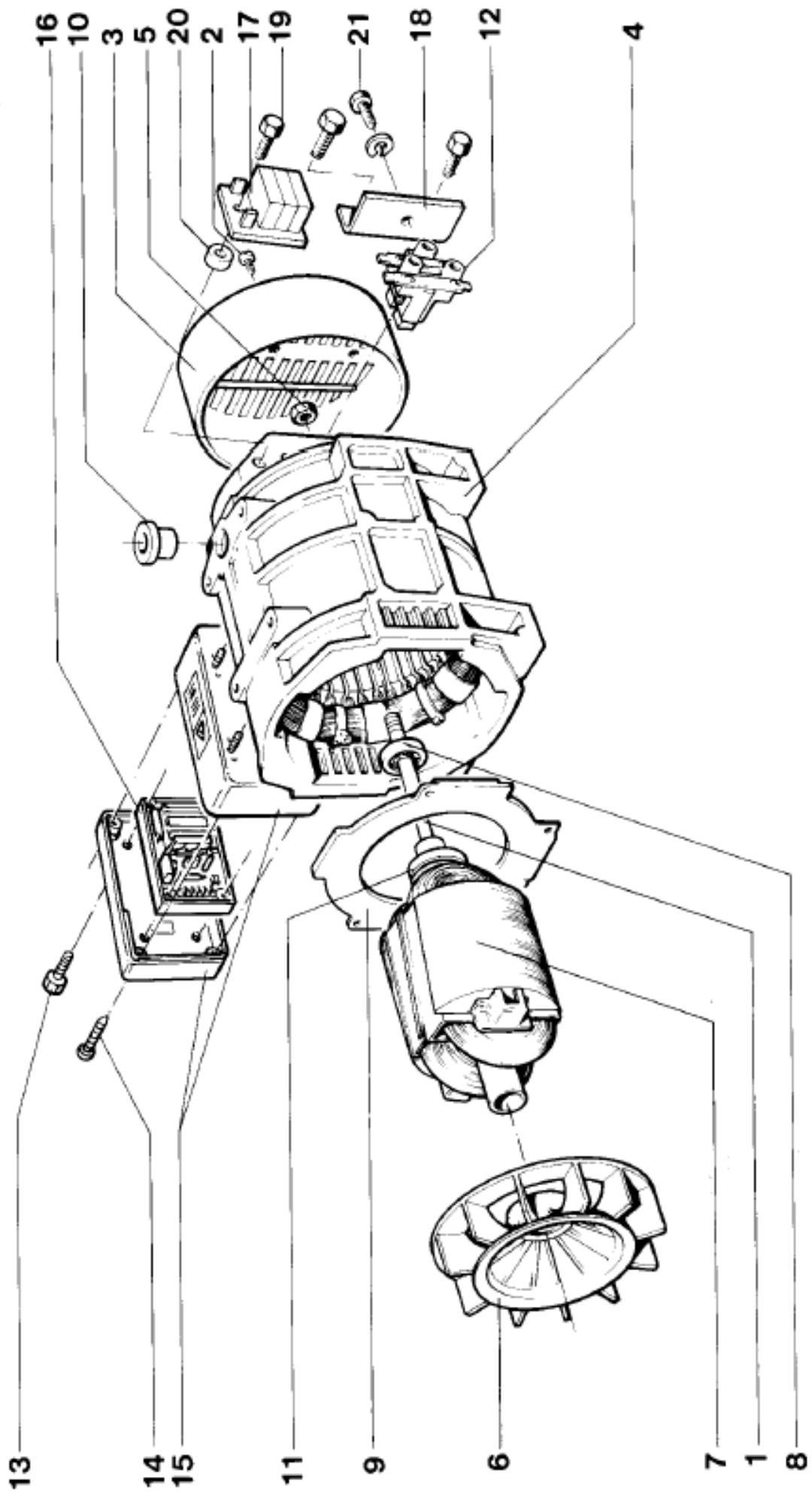

Notes:

Notes:

A.C. GENERATOR WARRANTY

DEFECTS AFTER DELIVERY

We will make good by repair or, at our option, by the supply of a replacement, any fault which under proper use appears in the goods within the period specified on Clause 12, and is found on examination by us to be solely due to defective material and workmanship; provided that the defective part is promptly returned, carriage paid, with all identification numbers and marks intact, to our works or, if appropriate, to the Dealer who supplied the goods.

Any part repaired or replaced, under warranty, will be returned by MS free of charge (via sea freight if outside the UK).

We shall not be liable for any expenses which may be incurred in removing or replacing any part sent to us or inspection or in fitting any replacement supplied by us. We shall be under no liability for defects in any goods which have not been properly installed in accordance with MS recommended installation practices as detailed in the publications MS Installation, Service and Maintenance Manual and MS Application Guidelines, or which have been improperly stored or which have been repaired, adjusted or altered by any person except ourselves or our authorised agents, or in any second-hand goods, proprietary articles or goods not of our own manufacture although supplied by us, such articles and goods being covered by the warranty (if any) given by the separate manufacturers.

Any claim under this clause must contain full particulars of the alleged defect, the description of the goods, the date of purchase, and the name and address of the Vendor, the Serial Number (as shown on the manufacturers identification plate) or for Spares the order reference under which the goods were supplied. Our judgement in all cases of claims shall be final and conclusive and the claimant shall accept our decision on all questions as to defects and the exchange of a part or parts.

Our liability shall be fully discharged by either repair or replacement as above, and in any event shall not exceed the current list price of the defective goods.

Our liability under this clause shall be in lieu of any warranty or condition implied by law as to the quality or fitness for any particular purpose of the goods, and save as expressly provided in this clause we shall not be under any liability, whether in contract, tort or otherwise, in respect of defects in goods delivered or for any injury, damages or loss resulting from such defects or from any work undone in connection therewith.

WARRANTY PERIOD

A.C. Generators In respect of a.c. generators the Warranty Period is eighteen months from the date when the goods have been notified as ready for despatch by MS or twelve months from the date of first commissioning (whichever is the shorter period)

Spares. In respect of Spares the Warranty Period is three months from the date of despatch by us or on fitment whichever is the earlier. These periods are subject to the exclusions and conditions specified in Clause 11.

MACHINE SERIAL NUMBER

--



MARKON SAWAFUJI LTD
3 LANDS END WAY
OAKHAM
RUTLAND
LE15 6RB
England
Telephone: 44 (0) 1572 723811
Fax: 44 (0) 1572 756856

PO BOX 17
BARNACK ROAD
STAMFORD
LINCOLNSHIRE
PE9 2NB
ENGLAND
Telephone: 44 (0) 1780 484000
Fax: 44 (0) 1780 484100
www.newage-avkseg.com

SUBSIDIARY COMPANIES

- | | | | | | |
|---|------------------|---|----|------------------|---|
| 1 | AUSTRALIA | NEWAGE ENGINEERS PTY. LTD
PO Box 6027,
Baulkham Hills Business Centre,
Baulkham Hills NSW 2153
Tel: (61) 2 9680 2299
Fax: (61) 2 9680 1545 | 6 | JAPAN | NEWAGE INTERNATIONAL JAPAN
8-5- 302 Kashima
Hachioji-shi
Tokyo, 192-03
Telefon: (81) 426 77 2881
Fax (81) 426 77 2884 |
| 2 | CHINA | WUXI NEWAGE ALTERNATORS
LTD
Plot 49-A, Xiang Jiang Road
Wuxi High – Technical Industrial
Dev.Zone
Wuxi, Jiangsu 214028
PR of China
Tel.: (86) 51 027 63313
Fax: (86) 51 052 17673 | 7 | MEXICO | STAMFORD MEXICO, S de RL de CV
Av. Circuito Mexico No. 185
Parque Industrial 3 Naciones
San Luis Potosi, SLP
C.P. 78395
Tel: (52) 48 26 84 00
Fax: (52) 48 26 84 05 |
| 3 | GERMANY | AvK DEUTSCHLAND GmbH & Co.
KG
Niederlassung Dreieich
Benzstrasse 47-49
63303 Dreieich
Tel: (49) 61 03 50 39 0
Fax: (49) 61 03 50 39 40 | 8 | NORWAY | NEWAGE NORGE A/S
Økern Naeringspark,
Kabeigt 5
Postboks 28,
Økern, 0508 Oslo
Tel: Oslo (47) 22 97 44 44
Fax: (47) 22 97 44 45 |
| 4 | INDIA | NEWAGE ELECTRICAL LTD
C33 Midc,
Ahmednagar 414111,
Maharashtra
Tel: (91) 241 778 224
Fax: (91) 241 777 494 | 9 | SINGAPORE | NEWAGE ASIA PACIFIC PTE LTD
10 Toh Guan Road #05-03
TT International Tradepark
Singapore 608838
Tel: (65) 794 3730
Fax: (65) 898 9065 |
| 5 | ITALY | NEWAGE ITALIA Srl
Via Triboniano,
20156 Milan
Tel: (39) 02 380 00714
Fax: (39) 02 380 03664 | 10 | SPAIN | STAMFORD IBERICA SA
Poligono Industrial "Los Linares"
Avda.de Fuenlabrada, 38
E-28970 HUMANES DE MADRID
Tel: (34) 91 498 2000
Fax : (34) 91 498 2004 |